

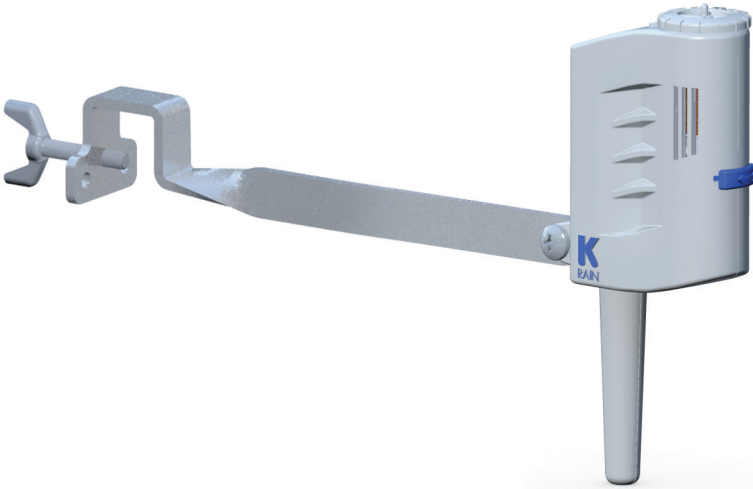

Universal Wireless Rain/Freeze Sensor



OWNER'S MANUAL AND INSTALLATION INSTRUCTIONS

3208-UWRFS

TABLE OF CONTENTS

Introduction	2
Features & Benefits	3
Universal Rain Sensor Receiver Components	4
Rain/Freeze Sensor Components	5
Installing the Universal Rain Sensor Receiver into Controllers	6
With Sensor Terminals	6
Without Sensor Terminals	6
Wiring for all Installation Methods	7
Check to verify correct wiring.	7
Mounting the Universal Rain Sensor Receiver	8
Pairing with the Wireless Rain Sensor	8
Mounting the Rain Sensor	9
Standard Flat Mounting	9
Gutter Mounting	9
Tips for Mounting.	9
Adjustments And Operation	10
Bypassing The Rain Sensor	10
Specifications.	11
Troubleshooting	12
FCC Declaration of Conformity	13
FCC Notice	14
Warranty	back cover

INTRODUCTION

Thank you for selecting the K-Rain® Universal Wireless Rain/Freeze Sensor.

The **Universal Rain Sensor Receiver** allows installation with most irrigation controllers – regardless of the manufacturer. Once successfully paired with the K-Rain Wireless Rain/Freeze Sensor, the controller will be able to expertly manage water efficiency by suspending watering during rain and/or freeze periods.

After a set amount of rain has fallen and/or freezing temperatures exist, the sensor will trigger the controller to suspend watering. The freeze sensor interrupts your sprinklers and reduces the hazards of standing water freezing on your driveway, sidewalks, and patios when temperatures drop below 37°F [3°C]. Once the rain sensor has dried sufficiently, the sensor allows normal sprinkler operation. Works with most new and existing sprinkler systems. This rain sensor will NOT work with open circuit controllers.

WARNING: *Use with 24V AC power only! Connecting this sensor to 120V or 240V AC power may result in severe equipment damage.*

FEATURES & BENEFITS

Universal Wireless Rain/Freeze Sensor

- **Flexibility.** The Universal Wireless Rain/Freeze Sensor can be paired with nearly any manufacturer's controller, providing a cost efficient option to add a wireless rain sensor to most irrigation systems.
- The K-Rain Wireless Rain/Freeze Sensor (model 3208-UWRFS) can be paired with multiple K-Rain Pro EX 2.0 Wifi enabled controllers within range, providing additional value for the end user.
- **Quick Installation and Programming.** The Universal Wireless Rain/Freeze Sensor provides the advantage of extremely quick installation.
- **Weather Resistant.** Engineered with impact modified, UV resistant polymer for outdoor exposure.
- **Maintenance Free.** No batteries to replace.
- **2 in 1 Mounting.** Provides flexible installation with standard flat and gutter mounting.
- Model 3208-UWRFS includes a freeze sensor that prevents the irrigation system from starting when temperatures drop to 37°F or below.

UNIVERSAL WIRELESS RAIN/FREEZE SENSOR RECEIVER COMPONENTS

- 1. Pair Button.** Initiates the pairing process.
- 2. Paired LED.** Displays status of pairing to the Wireless Rain Sensor. The LED will flash green for pairing process, stay green under normal conditions and turn flashing red after 24 hours from last successful pairing to indicate connection loss.
- 3. Suspended LED.** Indicates program suspension due to a rain or freeze event. The LED will be off normally and will turn red whenever a rain or freeze event occurs.
- 4. Battery LED.** Indicates health of the rain sensor battery. The LED will be green at good battery health and turn red when battery life is under 10%.
- 5. Radio Antenna.** Receives wireless signal from the rain sensor, up to 300 feet.
- 6. Wiring Harness.** Includes 2 yellow sensor wires, one red 24V AC power wire and one black common wire.

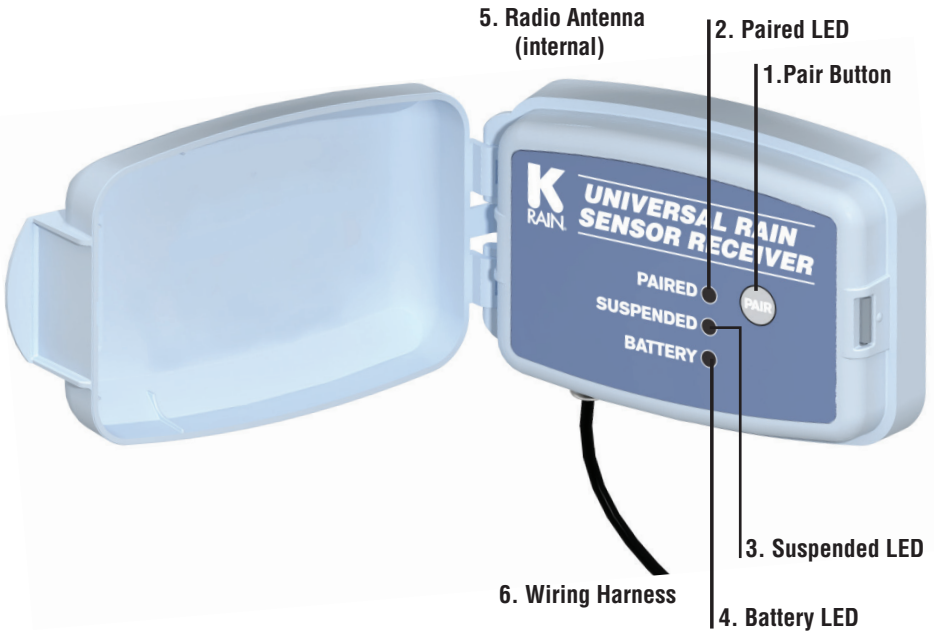

RAIN/FREEZE SENSOR COMPONENTS

- 1. Manual Test Pin.** Press and hold for three seconds to confirm proper operation.
 - 2. Vent Adjustment Tab.** Used to adjust the dry out time of the sensor. Depending on weather conditions, the farther open the vent windows, the sooner the unit will dry out and let the controller resume normal operations.
 - 3. Mounting Arm.** Metal extension arm for mounting the sensor.
 - 4. Rainfall Adjustment Cap.** The rain sensor cap can be adjusted to suspend watering when rainfall amounts of 1/8" (minimum setting) through 1/2" or more has fallen.
 - 5. Freeze Sensor.** Prevents the irrigation system from starting when temperatures drop to 37°F or below. When temperatures rise above 37°F, the sensor will enable automatic watering.
 - 6. Radio Antenna.** Transmits a wireless signal to the receiver.
- NOTE:** *Unit needs to be mounted with the radio antenna in a vertical position.*
- 7. Battery / Transfer Signal LED.** Pressing the Manual Test Pin for three seconds allows the user to see the LED flashing ON / OFF; indicating that the battery is functioning and is transmitting the signal to receiver.

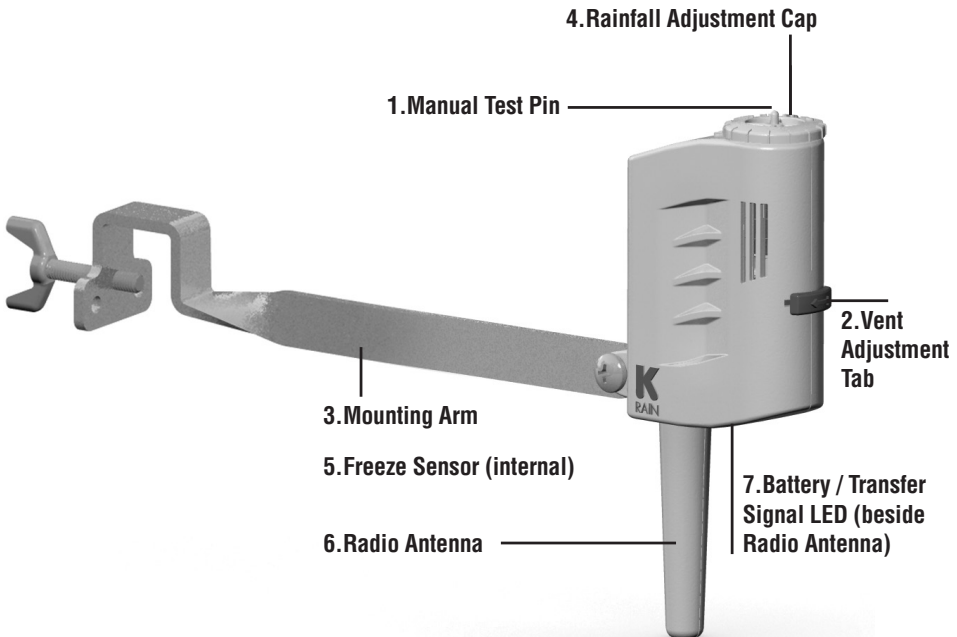

INSTALLATION

Installing the K-Rain Universal Rain/Freeze Sensor Receiver into controllers WITH sensor terminals.

Find the controller sensor terminals (generally marked “SENSOR”, “SEN” or “S”) and attach the yellow Universal Rain Sensor control wires directly to these terminals in any order. Next install the red power wire to the positive terminal (generally marked “VT” or “24VAC”) and the black common wire to the common terminal (generally marked “C” or “COM”) or the neutral 24VAC terminal.

NOTES:

- There may be a jumper tab or wire between the sensor terminals that must be removed.
- If a rain sensor is removed, the preinstalled jumper wire **MUST** be reinstalled on the SENSOR terminals.
- Controllers with global override and/or switch must be active/on in order for the sensor to work properly.

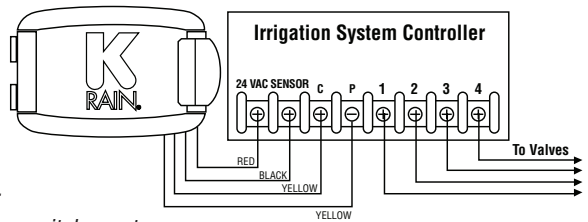

Installing the K-Rain Universal Rain Sensor Receiver into controllers WITHOUT sensor terminals.

- a. *WITHOUT* pump start relay/master valve (Fig. 1). Find the controller common terminal (generally marked “C” or “COM”) and attach one yellow Universal Sensor wire directly to the terminal. Locate the second yellow Universal Sensor wire and connect directly to the field common valve wire.

NOTE: The common wire to the valves does not have to be interrupted at the controller. Rain sensor may be wired anywhere along the common wire line.

FIGURE 1:

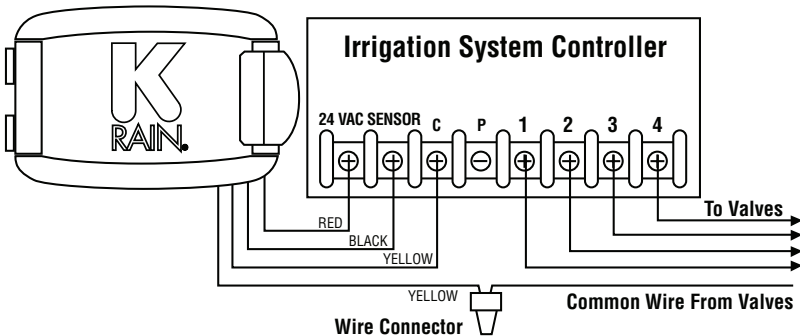

- b. *WITH pump start relay/master valve (Fig. 2).* Locate the common wire to the solenoid valves and the common wire lead to the coil of the relay that starts the pump. If these two wires are connected to the “common” terminal on the controller, disconnect both of them. Twist these two wires together along with one yellow wire from the Universal Rain Sensor and secure with a wire nut. Attach the other yellow wire of the rain sensor to the “common” terminal on the controller.

FIGURE 2:

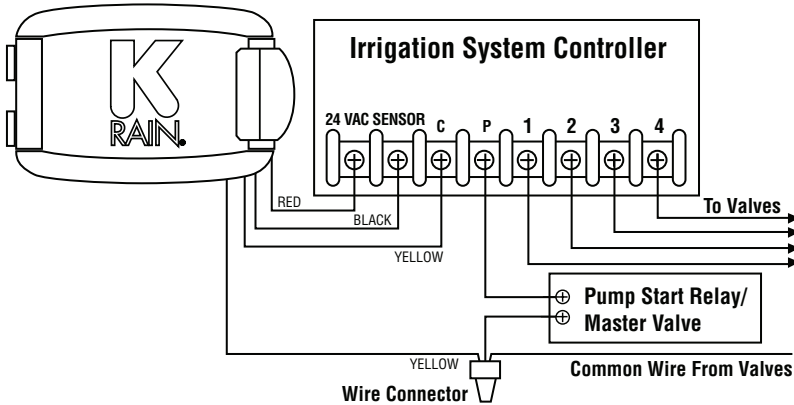

WIRING

For all installation methods:

Once the rain sensor receiver is mounted, run the wires to the controller using wire clips every few feet to fasten it. If an extension to the wires provided is needed, use the following table to determine the minimum wire gauge needed:

Extension Needed:	25-50 ft.	50-100 ft.	100 ft. or more
Minimum Wire Gauge:	20 AWG	18 AWG	16 AWG

Check to verify correct wiring:

Turn on one zone of the sprinkler system that is visible while you are in reach of the rain sensor. Manually depress the manual test pin at top of the rain sensor until you hear the switch “click” off. The sprinkler zone should stop instantly. If it does not, check wiring for correct installation.

MOUNTING THE UNIVERSAL RAIN SENSOR RECEIVER

- Remove the Back Housing from the Main Housing using the side clips shown here.
- Mount the Back Housing through the 3 mounting holes utilizing the supplied hardware (fig.3).
- Once the Back Housing is installed, attach the Main Housing with the 2 side clips (fig.3).
- Take care to ensure the supplied rubber wiring harness grommet seals correctly against the 2 halves of the housing.

FIGURE 3:

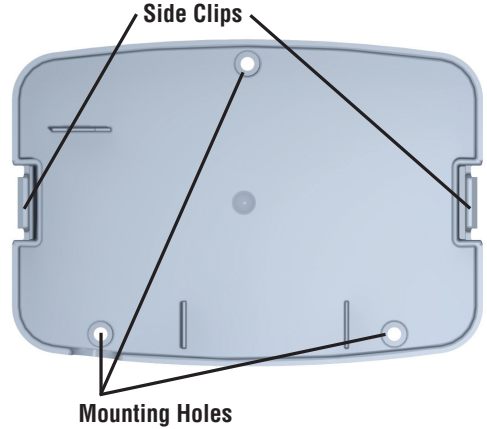

PAIRING WITH THE WIRELESS RAIN SENSOR

Press and hold the **PAIR** button on the Universal Rain Sensor Receiver for at least 3 seconds until the green **PAIRED LED** begins flashing rapidly (fig.4).

Next, press and hold the **MANUAL TEST PIN** on the Wireless Rain/Freeze Sensor for at least 3 seconds. The **PAIRED** and **BATTERY LEDs** will both display solid in green upon successful pairing (fig.5).

FIGURE 4:

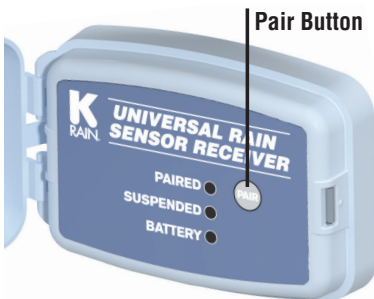
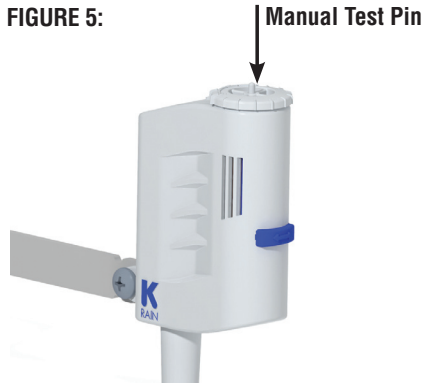

FIGURE 5:



MOUNTING THE RAIN SENSOR

Standard Flat Mounting

Mount the sensor on a surface that is unobstructed to rain fall, but away from the path of the sprinkler water spray.

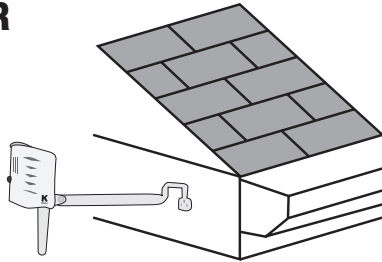

Gutter Mounting

Allows the rain sensor to be mounted directly to the side of the gutter. Position the gutter mount on the edge of the gutter and twist the thumbscrew to secure it in place.

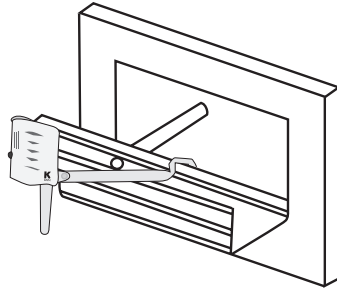

Tips for mounting

- a. When looking for a suitable location such as the side of a building or a post, positioning the Rain Sensor closer to the controller will help to avoid interference to the wireless signal.
- b. Mount in the highest possible position where rain can fall directly upon the rain sensor.
- c. The rain sensor mounting location will affect the reset rate (amount of time it takes the rain sensor to dry out sufficiently for the sprinkler system to reactivate). For example, mounting the rain sensor on a very sunny, southeastern end of a building may cause the rain sensor to dry out sooner than desired. Similarly, mounting on the northern end of a building with constant shade may keep the rain sensor from drying out at all. Some experimentation with the “vent adjustment tab” will usually yield satisfactory results.

ADJUSTMENTS AND OPERATION

When the Rain Sensor activates due to sufficient rainfall (after rainfall quantities of 1/8" through 1/2" or more), the sprinkler system will become inactive until the moisture-absorbent discs inside the Rain Sensor have dried out. To adjust to the desired quantity of rainfall, rotate the Rainfall Adjustment Cap on the rain sensor housing to the range desired (See Fig. 3).

FIGURE 3:

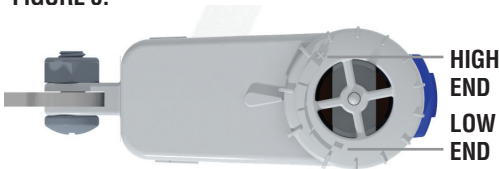

Adjust the Rainfall Adjustment Cap to the amount of rainfall you wish to trigger the rain sensor to suspend watering. Low end= 1/8", high end=1/2"

The time that it takes the rain sensor to reset for normal sprinkler operation after the rain has stopped is determined by weather conditions (wind, sunlight, humidity, etc.). These conditions will determine how fast the hygroscopic discs will dry out, the same conditions your soil experiences.

Note that there is an adjustment capability on the rain sensor that will slow down the reset rate. By turning the "Vent Adjustment Tab" (See Figure 4) to completely or partially cover the ventilation holes, the hygroscopic discs will dry more slowly. This adjustment can compensate for an "overly sunny" installation location or peculiar soil conditions.

Experimenting with the Vent Adjustment Tab will best determine the ideal vent setting.

FIGURE 4



BYPASSING THE RAIN SENSOR

The Universal Rain Sensor can be temporarily bypassed or deactivated using any one of the following methods:

- Use the controller's sensor bypass switch (if equipped).
- Temporarily disconnect the Universal Rain Sensor from the controller's wiring.

NOTE: Always disconnect power to the controller *BEFORE* performing any wiring tasks.

SPECIFICATIONS

Mounting: Supplied screws through Back Housing for standard flat and gutter installation.

Rating: 3 amp, 24 V AC, NC (Normally Close contacts)

Operating Temperature Range: 14°F to 149°F (-10°C to 65°C)

Hardware: Stainless steel

Mounting: 2 in 1 bracket for standard flat and gutter installation

Sensor Type: Industry-standard hygroscopic disc stack with adjustable rainfall sensitivity

Housing: UV-resistant engineered polymer

Warranty: Five years

Rain/Freeze Wireless Range: Up to 300 feet or 120 meters
(Line of Sight)

Freeze Set Point: 37°F

Control Wire: 3 feet outdoor-rated, 16 gauge cable, UL approved

Average Battery Life: Designed to operate up to 8 years
(under normal conditions)

TROUBLESHOOTING

Follow these simple steps before replacing your rain sensor:

System will not activate:

- a. Check to see that the paired Wireless Rain Sensor discs are dry and switch “clicks” on and off freely by pressing the top of the spindle.
- b. Look for breaks in the wire leading to the Universal Rain Sensor and check all wire junctions.
- c. Check to ensure successful pairing between Universal Rain Sensor and Wireless Rain Sensor.
- d. Inspect paired Wireless Rain Sensor for damage and ensure proper functionality of unit.
- e. The rain sensor is wired to function with most controllers (normally closed). If you are unable to make the sensor work with the suggestions above you may have a unique controller (normally open).
- f. Ensure paired rain sensor has been installed in a location within good connection range to Universal Rain Sensor Receiver.
- g. Check controller bypass feature/switch settings.

System will not shut off even after heavy rainfall:

- a. Check wiring for correct installation (See “Installation” section).
- b. Check sensitivity setting on paired rain sensor, and move the cap to a more sensitive setting. The rain sensor is an accurate rain gauge and can be verified by setting up a “tube” type rain gauge in the same vicinity and making periodic readings.
- c. Check for obstructions to rainfall such as overhangs, trees or walls.
- d. Ensure paired rain sensor has been installed in a location within good connection range to Universal Rain Sensor.
- e. Ensure unit is successfully paired.

FCC DECLARATION OF CONFORMITY

Trade Name	Wireless Rain Freeze Sensor
Model Number	3208-WRFS
Compliance Test Report Number	16FAB01000511
Compliance Test Report Date	March 22, 2016
Responsible Party	K-Rain Manufacturing Corporation
Address	1640 Australian Avenue Riviera Beach, FL 33404
Telephone	561-844-1002

This equipment has been tested and found to comply with the limits for class B digital devices, pursuant to part 15 of the FCC Rules. These limits are designed to provide reasonable protection against harmful interference in a residential installation. This equipment generates, uses, and can radiate radio frequency energy and if not installed and used in accordance with the instructions, may cause harmful interference to radio communications. However, there is no guarantee that interference will not occur in a particular installation.

If this equipment does cause harmful interference to radio or television reception, please refer to your user's manual for instructions on correcting the problem. The undersigned, hereby declare that the equipment specified above conforms to the above requirements.

FCC NOTICE

Sensor FCC ID:

***This device complies with FCC rules Part 15.
Operation is subject to the following two conditions:***

1. This device may not cause harmful interference and
2. This device must accept any interference received, including interference that may cause undesired operation.
3. This equipment has been tested and found to comply with the limits for class B digital devices, pursuant to part 15 of the FCC Rules. These limits are designed to provide reasonable protection against harmful interference in a residential installation. This equipment generates, uses, and can radiate radio frequency energy and if not installed and used in accordance with the instructions, may cause harmful interference to radio communications. However, there is no guarantee that interference will not occur in a particular installation. If this equipment does cause harmful interference to radio or television reception, which can be determined by turning the equipment on and off, the user is encouraged to try to correct the interference by one or more of the following measures:
 - Reorient or relocate the receiving antenna
 - Increase the separation between the equipment and the receiver
 - Connect the equipment to an outlet on a circuit different from that to which the receiver is connected
 - Consult the dealer or an experienced radio/TV technician for help

The user is cautioned that changes and modifications made to the equipment without the approval of the manufacturer could void the user's authority to operate this equipment.

MODEL

3208-UWRFS Wireless Rain/Freeze Sensor

WARRANTY

K-Rain Manufacturing warrants that its products will be free from materials and workmanship defects for a period of 5 years. With proof of purchase provided, K-Rain will replace, free of charge, the part or parts found to be defective under normal use and service for the warranty period. Prior to replacement, K-Rain reserves the right to inspect and authorize the defective part or parts; all defective material returns must be authorized in writing by K-Rain. Liability under this warranty is limited solely to the replacement or repair of defective parts.

This warranty is given expressly and in place of all other expressed or implied warranties including but not limited to warranties regarding fitness for use of merchantability. No agent or representative has authority to waive or alter this warranty.



K-Rain Manufacturing Corp.

1640 Australian Avenue

Riviera Beach, FL 33404

561.844.1002 800.735.7246

561.842.9493 FAX

www.krain.com

© K-Rain Manufacturing Corp.
AN ISO 9001 CERTIFIED COMPANY